



Carbon Monoxide Transmitter E2615-CO



Features

- Maintenance free sensor
- User selectable output 4-20 mA / 0-10 V
- Range of compact wall mount enclosures
- Low cost for volume HVAC applications

Specifications

Sensor type	Electrochemical
Sampling method	Diffusion
Detection range	0-300 ppm
Resolution	1 ppm
Maximum overload	1000 ppm
Response time T90	< 45 s
Sensor protection	Microporous PTFE dust filter
Warm-up time	≤ 1 min
Analog output	4-20 mA / 0-10 V, user settable
Power supply	24 VDC ± 20%
Power consumption	< 1 W
Sensor lifetime	≥ 10 years
Sensitivity drift	< ± 20% in 5 years
Indoors enclosure IP20 version	White, ivory or black ABS plastic, wall mount, protection class IP20
Weatherproof enclosure IP65 version	Light or dark grey ABS plastic, wall mount, protection class IP65
Operating conditions	-20...+40 °C recommended -20...+50 °C intermittently 10...95 %RH non-condensing, pressure 0,9...1,1 atm
EMC Emissions	To EN 61000-6-3, EN 61326-1
EMC Immunity	To EN 61000-6-1, EN 61000-6-2

IP65 Enclosures

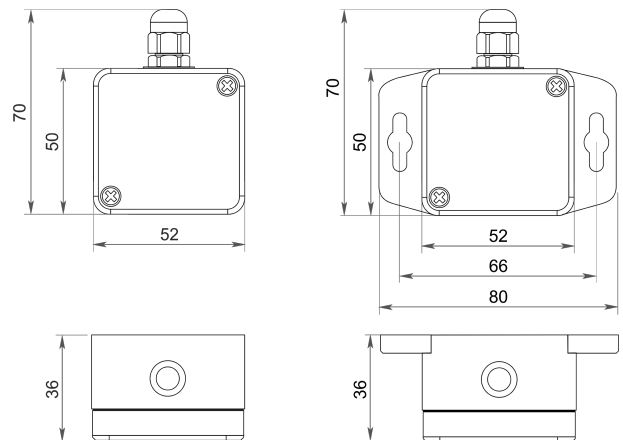

IP20 Enclosures

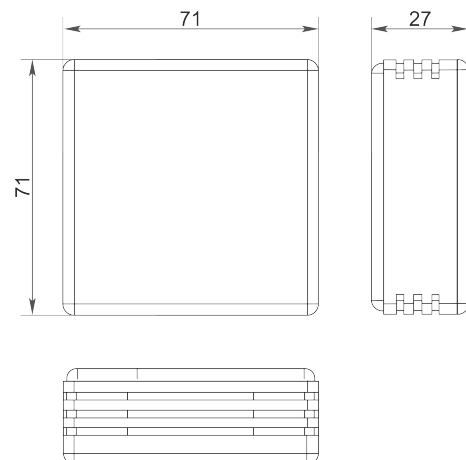

Connection diagrams

3-wire 4-20 mA output

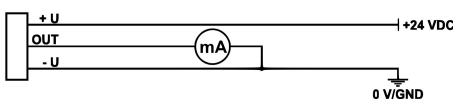

3-wire 0-10 V output

