

## U5200 Industrial Pressure Transducer



- High Accuracy
- CE Compliant
- Compact
- Variety of Pressure Ports and Electrical Configurations
- Optional Stainless Steel Snubber
- Weatherproof
- Gage, Sealed, Absolute, Compound

### DESCRIPTION

The U5200 pressure transducers from the UltraStable™ line of MEAS, with their modular design, offer maximum flexibility for different configurations. This latest series features high accuracy and a quick turnaround for demanding commercial and heavy industrial applications. This series is suitable for measurement of liquid or gas pressure, even for difficult media such as contaminated water, steam, and mildly corrosive fluids.

The wetted material is made of 316L stainless steel and the transducer's durability is excellent with no o-rings, welds or organics exposed to the pressure media. The U5200 is weatherproof and exceeds the latest heavy industrial CE requirements including surge protection. The circuit is protected from reverse wiring at input and short circuit at output.

This product is geared to the OEM customer for low to mid volumes. MEAS stands ready to provide a custom design of the U5200 where the volume and application warrants. Additional configurations not listed are either available or possible. Please inquire for further information.

### FEATURES

- Heavy Industrial CE Approval
- 10 V/m EMI Protection
- Reverse Polarity Protection on Input
- Short Circuit Protection on Output
- Up to  $\pm 0.1\%$  Accuracy
- Up to  $\pm 0.75\%$  Total Error Band
- Compact Outline
- $-40^{\circ}\text{C}$  to  $+125^{\circ}\text{C}$  Operating Temperature
- Weatherproof

### APPLICATIONS

- Industrial Process Control and Monitoring
- Advanced HVAC Systems
- Refrigeration Systems
- Automotive Test Stands
- Off-Road Vehicles
- Pumps and Compressors
- Hydraulic/Pneumatic Systems
- Agriculture Equipment
- Energy Generation and Management

### STANDARD RANGES

Range (psi)	Range (Bar)	Gage	Sealed	Absolute	Compound
0 to 002	0 to .14	•	•	•	•
0 to 005	0 to .35	•	•	•	•
0 to 015	0 to 001	•	•	•	•
0 to 030	0 to 002	•	•	•	•
0 to 050	0 to 3.5	•	•	•	•
0 to 100	0 to 007	•	•	•	•
0 to 200	0 to 014	•	•	•	•
0 to 300	0 to 020	•	•	•	•
0 to 500	0 to 035	•	•	•	•
0 to 01k	0 to 070	•	•	•	•
0 to 03k	0 to 200	•	•	•	•
0 to 05k	0 to 350	•	•	•	•
0 to 10k	0 to 700	•	•	•	•

Intermediate ranges available upon request.

# U5200 Industrial Pressure Transducer

## PERFORMANCE SPECIFICATIONS

Ambient Temperature: 25°C (unless otherwise specified)

PARAMETERS	MIN	TYP	MAX	UNITS	NOTES
Accuracy (RSS of linearity, hysteresis, and repeatability)	-0.5		0.5	%F.S. BFSL	≤ 2psi @ 25°C
	-0.25		0.25	%F.S. BFSL	> 2psi and ≤ 5psi @ 25°C
	-0.1		0.1	%F.S. BFSL	> 5psi and ≤ 500psi @ 25°C
	-0.25		0.25	%F.S. BFSL	> 500psi and ≤ 5000psi @ 25°C
	-0.75		0.75	%F.S. BFSL	> 5000psi @ 25°C
Isolation, Body to any Lead	100			MΩ	@500VDC
Dielectric Strength			2	mA	@500VAC, 1min
Pressure Cycles	1.00E+6			0~FS Cycles	
Proof Pressure	3X		20k psi	Rated	
Burst Pressure	4X		20k psi	Rated	
Long Term Stability (1 year)	-0.1		0.1	%F.S.	
	-1.25		1.25	%F.S.	≤ 2psi
	-1.0		1.0	%F.S.	> 2psi and ≤ 5psi
	-0.75		0.75	%F.S.	> 5psi and ≤ 5000psi
	-1.25		1.25	%F.S.	> 5000psi
Compensated Temperature	-20		+85	°C	
Operating Temperature	-40		+125	°C	Except cable 105°C max
Storage Temperature	-40		+125	°C	Except cable 105°C max
Load Resistance (R <sub>L</sub> )	R <sub>L</sub> > 100k			Ω	Voltage Output
Load Resistance (R <sub>L</sub> )	< (Supply Voltage -9V) / 0.02A			Ω	Current Output
Current Consumption			5	mA	Voltage Output
Rise Time (10% to 90%)	<2ms (Voltage Output); <3ms (Current Output); Without Snubber				
Pressure Port Material	316L Stainless Steel				
Shock	50g, 11msec Half Sine Shock per MIL-STD-202G, Method 213B, Condition A				
Vibration	±20g, MIL-STD-810C, Procedure 514.2, Fig 514.2-2, Curve L				

For custom configurations, consult factory.

### Notes

**Compensated Temperature:** The temperature range over which the product will produce an output proportional to pressure within the specified performance limits.

**Operating Temperature:** The temperature range over which the product will produce an output proportional to pressure but may not remain within the specified performance limits.

**Storage Temperature:** The temperature range over which the product can be stored safely in occasions without pressure applied or power input and remains rated performance. Beyond this temperature range may cause permanent damage to the product.

All configurations are built with supply voltage reverse and output short-circuit protections.

### CE Compliance

EN 55022 Emissions Class A & B

IEC 61000-4-2 Electrostatic Discharge Immunity (8kV contact/15kV air)

IEC 61000-4-3 Radiated, Radio-Frequency Electromagnetic Field Immunity (10V/m, 80M-1GHz)

IEC 61000-4-4 Electrical Fast Transient Immunity (1kV)

IEC 61000-4-5 Surge Immunity (V+ to V-: ±2KV/42Ω; L to Case: ±1KV/12Ω; V- to V<sub>0</sub>: ±1KV/42Ω)

IEC 61000-4-6 Immunity to Conducted Disturbances Induced by Radio Frequency

Fields (150K-80MHz, 10V level for voltage output models, 3V level for current output model)

IEC 61000-4-9 Pulse Magnetic Field Immunity (100A/m peak)

For all CE compliance tests, max allowed output deviation ±1.5 %F.S.

# U5200 Industrial Pressure Transducer

## DIMENSIONS [mm]

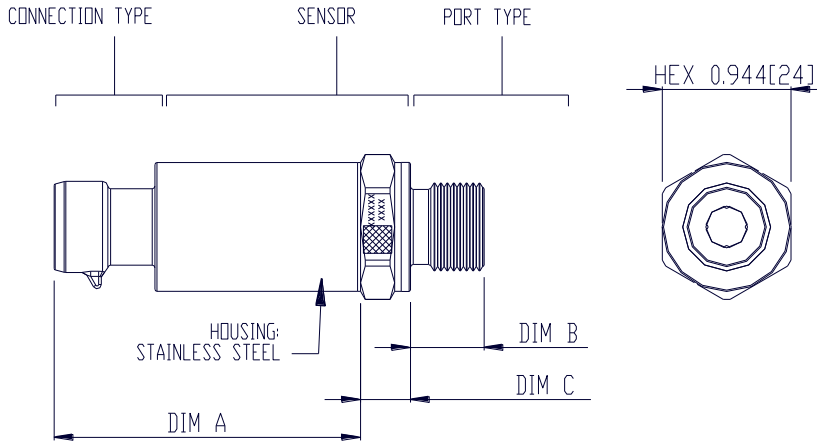

CODE	CONNECTION TYPE	DIM A
1	CABLE 2 FT	2.19 [55.6]
E	CABLE 3 FT	2.19 [55.6]
2	CABLE 4 FT	2.19 [55.6]
3	CABLE 10 FT	2.19 [55.6]
4	PACKARD CONNECTOR A	2.25 [57.2]
5	BAYONET CONNECTOR	2.11 [53.6]
6	FORM C	1.95 [49.5]
7	FORM A	2.10 [53.3]
9	PACKARD CONNECTOR B	2.25 [57.2]
D	M12 CONNECTOR	1.95 [49.5]
M	CABLE 1 M	2.19 [55.6]
N	CABLE 2 M	2.19 [55.6]
P	CABLE 5 M	2.19 [55.6]
R	CABLE 10 M	2.19 [55.6]
A	AMP CONNECTOR	2.10 [53.3]
S	SUMITOMO CONNECTOR	1.95 [49.5]
C	1/2" NPT CONDUIT	2.10 [53.3]

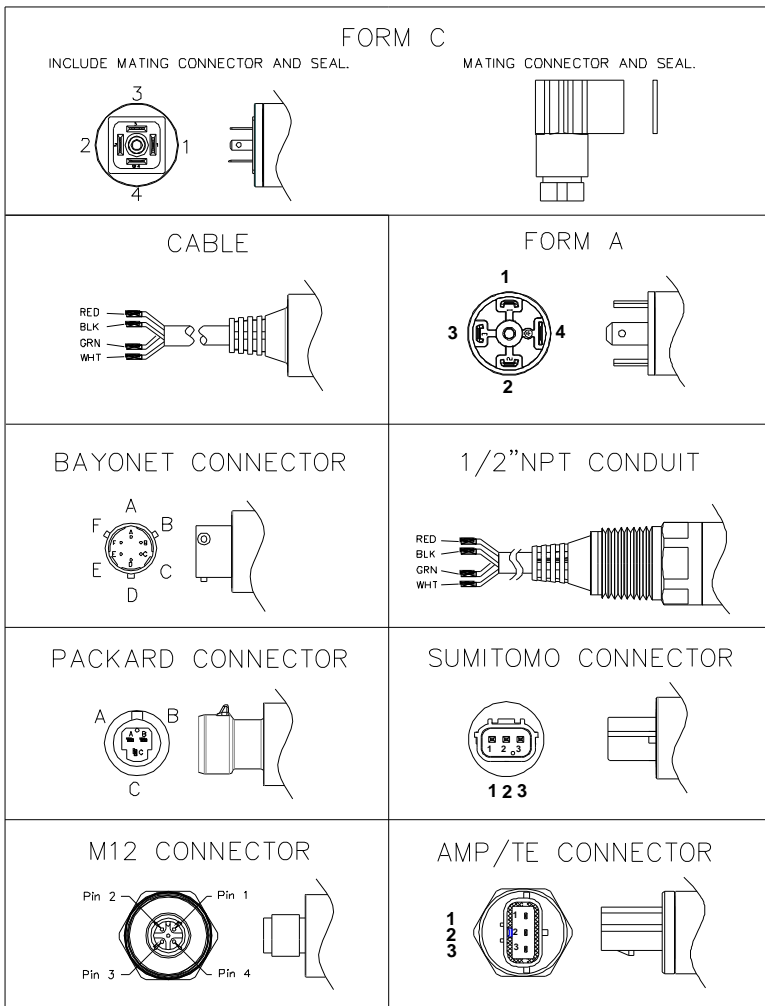

PRESSURE PORT TYPE			
CODE	PORT	DIM B	DIM C REF.
2	1/4-19 BSPP	0.470 [11.94]	0.366 [9.3]
3	G3/8 JIS B2351	0.540 [13.72]	0.366 [9.3]
4	7/16-20UNF MALE SAE J514 STRAIGHT THREAD O-RING BUNA-N 90SH-904	0.433 [11.0]	0.366 [9.3]
5	1/4-18 NPT	0.600 [15.24]	0.366 [9.3]
6	1/8-27 NPT	0.390 [9.91]	0.366 [9.3]
B	G1/4 JIS B2351	0.472 [11.94]	0.366 [9.3]
E	1/4-19 BSPT	0.500 [12.7]	0.366 [9.3]
F	1/4-19 BSPP FEMALE (without snubber)	0.621 [15.77]	0.366 [9.3]
P	7/16-20UNF FEMALE SAE J514 STRAIGHT THREAD WITH INTEGRAL VALVE DEPRESSOR	0.430 [10.92]	0.444 [11.28]
Q	M10 x 1.0 mm ISO 6149-2	0.374 [9.5]	0.366 [9.3]
S	M12 x 1.5 mm ISO 6149-2	0.433 [11.0]	0.366 [9.3]
U	G/14 DIN 3852 FORM E GASKET DIN3869-14 NBR	0.472 [11.94]	0.445 [11.3]
W	M20 x 1.5 mm ISO 6149-2	0.551 [14.0]	0.366 [9.3]
G	M14 x 1.5 mm ISO 6149-2	0.433 [11.0]	0.366 [9.3]

**Note:** Refer to installation instructions supplied with devices for recommended torque.

# U5200 Industrial Pressure Transducer

## WIRING

Current Output Wiring				
CONNECTION	+SUPPLY	-SUPPLY	NC. PINS	P REF VENT
Bayonet	A	B	C,D,E	F
Packard, A	A	B	C	Hole Through Connector
Packard, B	B	A	C	Hole Through Connector
Cable	RED	BLK		In Cable
1/2NPT CONDUIT	RED	BLK		In Cable
M12	1	3	2,4	Hole Through Connector
AMP/TE	1	2	3	Hole Through Connector
FORM C	1	2	3,4	Threads Through Connector
FORM A	1	2	3,4	Threads Through Connector
Sumitomo	1	2	3	Hole Through Connector

Voltage Output Wiring					
CONNECTION	+SUPPLY	+OUTPUT	COMMON	NC. PINS	P REF VENT
Bayonet	A	B	C	D,E	F
Packard, A	A	C	B		Hole Through Connector
Packard, B	B	C	A		Hole Through Connector
Cable	RED	WHT	BLK		In Cable
1/2NPT CONDUIT	RED	WHT	BLK		In Cable
M12	1	2	3	4	Hole Through Connector
AMP/TE	1	3	2		Hole Through Connector
FORM C	1	2	3	4	Threads Through Connector
FORM A	1	3	2	4	Threads Through Connector
Sumitomo	1	3	2		Hole Through Connector

**Notes:**

1. NC pins are reserved for factory use only. **Customers should not use these connections.**
2. For cable connection, the drain wire is internally terminated to pressure port.

# U5200 Industrial Pressure Transducer

## CONNECTION TYPES

CONNECTION TYPES				
CONNECTION	DESCRIPTION	MATING HOUSING P/N	MATING TERMINAL P/N	RUBBER SEAL P/N
<b>Bayonet</b>	BAYONET PTH-10-6P OR EQUIV	PT06A-10-6S MIL-C-26482	-	-
<b>Packard</b>	3-PIN METRI-PACK 150	12078090	12103881, QTY 3	-
<b>Cable &amp; 1/2NPT Conduit</b>	4-WIRE, 22 AWG, SHIELDED, PVC JACKET, 105 DEGC	-	-	-
<b>M12</b>	BINDER SERIES 713, 09 0439 387 04 OR EQUIV	4-POS FEMALE CONNECTOR	-	-
<b>AMP/TE</b>	AMP / TE 3-PIN ECONOSEAL J SERIES	174357-2 & 174358-7	171630-1 (AWG 20~24) 171662-1 (AWG 16~20) QTY 3	172746-1 (AWG 20~24) 172888-2 (AWG 16~20) QTY 3
<b>FORM C</b>	INDUSTRIAL STANDARD 9.4MM FORM C	HIRSCHMANN 933 024-100, OR, ATAM KD046000B7 (SEAL INCL.)	-	HIRSCHMANN 730 185-002
<b>FORM A</b>	DIN EN 175 301-803-A 18MM	HIRSCHMANN 931 969-100, OR, ATAM KA245000B4 (SEAL INCL.)	-	HIRSCHMANN 730 801-002
<b>Sumitomo</b>	SUMITOMO 3-PIN HV040	6189-6907	8100-3067 (AWG 20~22) 8100-3068 (AWG 16~18) QTY 3	7165-1075 (INS. DIA 1.1~1.6MM) 7176-0621 (INS. DIA 1.6~1.9MM) 7165-0622 (INS. DIA 1.8~2.2MM) QTY 3

**Note:** Transmitter of gage pressure type requires vent to atmosphere on the pressure reference side. This is accomplished via cable from the transmitter (the end of the cable should be terminated to clean and dry area) or through the customer mating connector/cable assembly which has internal vent path.

## WEATHERPROOF

WEATHER-PROOF RATING	
CONNECTION	IP CODE
<b>Bayonet</b>	IP67
<b>Packard</b>	IP66
<b>Cable</b>	IP67
<b>1/2NPT CONDUIT</b>	IP67
<b>M12</b>	IP67
<b>AMP/TE</b>	NOT RATED
<b>FORM C</b>	IP65
<b>FORM A</b>	IP65
<b>Sumitomo</b>	IP67

**Note:** Weatherproof ratings are met when the mating connectors are installed properly and the cable termination is to dry and clean area.

## OUTPUTS

CODE	OUTPUT SIGNAL	SUPPLY VOLTAGE
<b>3</b>	0.5 - 4.5V RATIOMETRIC	5 ± 0.25V PROTECTED to 30V
<b>4</b>	1 - 5V	8 - 30V
<b>5</b>	4 - 20mA	9 - 30V
<b>6</b>	0 - 5V	8 - 30V
<b>7</b>	0 - 10V	12 - 30V
<b>8</b>	1 - 6V	8 - 30V
<b>9</b>	0.5 - 4.5V	5 - 30V

# U5200 Industrial Pressure Transducer

## ORDERING INFORMATION

U52	3	1	-	0	0	00	0	5	-	100P	G
Model	Output Signal	Connection Type	-	0	Snubber	00	Label	Pressure Port	-	Pressure Range	Pressure Type
U52	3 = 0.5 – 4.5V Ratiometric 4 = 1 – 5V 5 = 4 – 20mA 6 = 0 – 5V 7 = 0 – 10V 8 = 1 – 6V 9 = 0.5 – 4.5V	1 = Cable 2 ft E = Cable 3 ft 2 = Cable 4 ft 3 = Cable 10 ft 4 = Packard Connector A 5 = Bayonet Connector 6 = Form C 7 = Form A 9 = Packard Connector B D = M12 Connector M = Cable 1 m N = Cable 2 m P = Cable 5 m R = Cable 10 m A = Amp Connector S = Sumitomo Connector C = 1/2" NPT Conduit	-	0	0 = No Snubber 1 = With Snubber	00	0 = Adhesive Label 1 = Laser Marking	2 = 1/4-19 BSPP 3 = G3/8 JIS B2351 4 = 7/16-20UNF Male SAE J514 Straight Thread O-Ring BUNA-N 90SH-904 5 = 1/4-18 NPT 6 = 1/8-27NPT B = G1/4 JIS B2351 E = 1/4-19 BSPT F = 1/4-19 BSPP Female P = 7/16-20UNF Female SAE J514 with Integral Valve Depressor Q = M10 x 1.0 mm ISO 6149-2 S = M12 x 1.5 mm ISO 6149-2 U = G1/4 DIN 3852 Form E Gasket DIN3869-14 NBR W = M20 x 1.5 mm ISO 6149-2 G = M14 x 1.5 mm ISO 6149-2	-	002P .14B 005P .35B 015P 001B 030P 002B 050P 3.5B 100P 007B 200P 014B 300P 020B 500P 035B 01KP 070B 03KP 200B 05KP 350B 10KP 700B	G = Gage S = Sealed A = Absolute C = Compound

Note: For Sumitomo and 1/2" NPT Conduit, contact factory for additional information.

### NORTH AMERICA

Measurement Specialties  
 45738 Northport Loop West  
 Fremont, CA 94538  
 Tel: 1-800-767-1888  
 Fax: 1-510-498-1578  
 Sales: [pfg.cs.amer@meas-spec.com](mailto:pfg.cs.amer@meas-spec.com)

### EUROPE

Measurement Specialties  
 (Europe), Ltd.  
 26 Rue des Dames  
 78340 Les Clayes-sous-Bois, France  
 Tel: +33 (0) 130 79 33 00  
 Fax: +33 (0) 134 81 03 59  
 Sales: [pfg.cs.emea@meas-spec.com](mailto:pfg.cs.emea@meas-spec.com)

### ASIA

Measurement Specialties  
 (China), Ltd.  
 No. 26 Langshan Road  
 Shenzhen High-Tech Park (North)  
 Nanshan District, Shenzhen 518057  
 China  
 Tel: +86 755 3330 5088  
 Fax: +86 755 3330 5099  
 Sales: [pfg.cs.asia@meas-spec.com](mailto:pfg.cs.asia@meas-spec.com)

The information in this sheet has been carefully reviewed and is believed to be accurate; however, no responsibility is assumed for inaccuracies. Furthermore, this information does not convey to the purchaser of such devices any license under the patent rights to the manufacturer. Measurement Specialties, Inc. reserves the right to make changes without further notice to any product herein. Measurement Specialties, Inc. makes no warranty, representation or guarantee regarding the suitability of its product for any particular purpose, nor does Measurement Specialties, Inc. assume any liability arising out of the application or use of any product or circuit and specifically disclaims any and all liability, including without limitation consequential or incidental damages. Typical parameters can and do vary in different applications. All operating parameters must be validated for each customer application by customer's technical experts. Measurement Specialties, Inc. does not convey any license under its patent rights nor the rights of others.