

Two-Color Pyrometer *Metis MQ11 and MQ22*

Two-Color- or Ratio- Pyrometers are typical names for pyrometers which measure temperatures from the ratio of radiation signals of two adjacent wavelengths as opposed to measuring the absolute intensity like single wavelength units do. The advantages for customers are the following:

- Gray bodies, i.e., targets with the same emissivity on both wavelengths, can be measured without emissivity setting.
- There is automatic compensation for dust, smoke or a dirty viewing window between pyrometer and target.
- Temperature errors are minimized if the target is too small or moving and the field of measurement can't be completely covered.

Metis Two-Color Pyrometers have universal applications, which means that they can also be used as two-color pyrometers as well as single wavelength pyrometers. In single wavelength mode, customers have the choice of deriving the analog output signal from shorter or longer wavelengths, or both. Using digital communication these temperature measurement results can be recorded and compared, to determine quickly whether the target is a „gray body“ radiator or not.

Chart 1: Temperature Ranges and Spectral Responses

Model	MQ11	MQ22
Spectral Response	0.7 – 1.1 µm	1.45 – 1.8 µm
Temperature-Range	600 – 1300°C 750 – 1800°C 900 – 2500°C	300 – 1000°C 350 – 1300°C



Lenses and Fiber-Optic Cable: The infrared energy radiated by the target is transferred via focusable lenses either directly on the detector (standard version) or on one end of a fiber optic cable. For installations with limited space, there is a fixed-focus miniature version. This feature offers the advantage of measuring the smallest spot (focused) or the average temperature of a bigger spot (out of focus) for the particular distance. For applications with need for refocusing the lens during operation, a **remote focusable optics** is available. If additional windows are necessary, they must offer similar optical characteristics. Lenses are made of BK7 (quartz glass), an optical glass which is highly transparent within the spectral range of *Metis MQ11*

Chart 2: Focusable Optics of *Metis* Standard Version

Optics	Distance	Spot Size Ø 300 – 1000°C 600 – 1300°C	Spot Size Ø other temper- ature ranges
OQ11-B0	250 mm	1.5 mm	1 mm
	500 mm	3.1 mm	2 mm
	750 mm	5.0 mm	3.1 mm
	1000 mm	6.9 mm	4.3 mm
	2000 mm	14.3 mm	8.5 mm
	3000 mm	22 mm	13 mm

The detector is sensitive to infrared radiation in an area called the **cone of vision**. For the spot size diameter Ø of this area at the shortest, medium and widest distances, when focused, please refer to **Chart 2**. The cone of vision diameter in front of the lens is max. 20 mm. This changes continuously in relation to the spot size diameter given in the chart. This area has to be kept free from any intervening objects. The spot size diameter for distances not given in the chart can be calculated by interpolation.

The spot size of the focusable lenses to be used with the *Metis MQ* Fiber-Optic version can be taken from **Charts 3 and 4**. The larger lens tube diameter of 25 mm offers the advantage of a smaller spot at the same distance. Fiber-optic versions are supplied with 2.5 m, single mode fibers, having a diameter of 0.2 mm, (0.4 mm zero scale 300°C or 600°C only). Longer cables with up to 20 m are available on request.

Chart 3: Focusable Optics of *Metis* Fiber-Optic Version

Optics with 25 mm Tube Ø	Distance	Spot Size Ø 300 – 1000°C 600 – 1300°C	Spot Size Ø other temper- ature ranges
OQ25-B0	140 mm	1 mm	0.5 mm
	500 mm	3.7 mm	2.5 mm
	750 mm	5.6 mm	3.8 mm
	1000 mm	7.7 mm	5 mm
	2000 mm	15.4 mm	10 mm
	3000 mm	23 mm	15 mm

Optics with 12 mm Tube Ø	Distance	Spot Size Ø 300 – 1000°C 600 – 1300°C	Spot Size Ø other temper- ature ranges
OQ12-C0	120 mm	2.2 mm	1.2 mm
	250 mm	5 mm	2.5 mm
	500 mm	12 mm	6 mm

Chart 4: Focusable Miniature Lens of Fiber-Optic Version

Note: Shorter distances with smaller spot sizes than shown in chart 1-3 are available on request.

Aiming Capabilities: *Metis MQ* Standard Pyrometers are available with 3 different solutions for aiming the sensor onto the target. The first, and most popular, method is the built-in laser pointer which is also helpful for focusing. The second is a sight-through optics version with reticle-defined target which is advantageous for applications where aiming onto hot, incandescent targets is needed. The viewing telescope is equipped with a dimmable sight attenuation filter to protect the eye. And finally, the third solution is a built-in b/w video camera for all applications where neither the laser nor the sight-through version can be used. This feature offers also possibilities for remote controlling of the heating process in dangerous environments. The fiber-optic version of *Metis* can be equipped with laser pointer only.

Temperature Output Signals: *Metis* Pyrometers offer a variety of analog and digital output signals for indication, recording, archiving and controlling of measured process temperatures. The isolated analog output is switch able from 0 to 4 to 20 mA. Zero- and full-scale temperatures are adjustable to cover any portion of the instrument's available temperature span to a minimum of 50°C.

There is a choice of 3 digital communication interfaces: **RS 232** or **RS 485** max. 57.6 kBd (internal) or **Profibus** (external).

Signal Filtering: For measuring and holding of the highest instantaneous temperature values, a **peak picker** (maximum value storage) is installed to compensate interruptions or attenuations in radiation caused by bursts of steam, smoke or dust. It can be either reset automatically or manually by an external contact closure or periodically by using preset clear time. In the automatic case, the highest temperature will be held in a dual storage and will be reset in only one of the two storages after preset clear time to avoid a decrease of the temperature output, should a short "cold" period appear just at the reset moment. The **exposition time** is the length of time it takes for the output signal to reach 90% of a step change in measured temperature. It can be used to filter out rapid variations in temperature and achieve a "more quiet" signal for control or display purposes.

The **PSCWin Software** is available for automatic or manual set up of the pyrometer, for recording and for saving of graphical or table files. At the same time, these files can be used for quality assurance purposes since the parameter settings are recorded as well. Minimum computer requirements are: 500 MHz clock frequency and Windows 95, 98, ME or XP operating systems.

Additional Specifications:

Measurement Uncertainty:	fullscale temperatures < 1500°C: 0.3% of measured value in °C + 1°C fullscale temperatures < 1800°C: 0.5% of measured value in °C + 1°C fullscale temperatures < 2500°C: 1% of measured value in °C
Repeatability:	0.1% of measured value in °C + 1°C
Speed of Response: t_{90}	2 ms with dynamic adaptation at low signal levels, adjustable up to 10 s
Analog Output Signal:	0 or 4 – 20 mA selectable, 500 Ω max. load
Digital Interface:	either RS 232 or RS 485 max. 57,6 kBd (standard supply), Profibus (optional)
Temperature Resolution:	analog < 0.1% of adjusted temperature range, digital 0.1°C
Ambient Temperature Range:	Pyrometer: operation -10 – 70°C, storage -20 – 70°C, Fiber Optic Cable and Lens: 0-250°C
Power Supply:	24 V AC/DC (12 – 30 V AC/DC), AC: 48 – 62 Hz, max. 7,5 VA
Isolation:	power supply, analog and digital output are galvanically isolated against each other and against housing
Housing and Rating:	extruded aluminium profile, IP 65 per DIN 40 050
Weight:	500 g
CE Label:	according to EU directives for electromagnetic immunity
Laser Pointer:	(optional) 650 nm, < 1 mW, class II per IEC 60825-1-3-4
Camera Modul:	PAL or NTSC
Video Signal:	isolated BAS signal about 1 V _{SS} at 75 Ω, CCIR standard, 50 Hz
Resolution:	black/white 628 x 582 pixel
Field of View:	266 to 380:1, depending on Model,distance and optics type
Signal Port:	cinch connector with SCART adapter connected to cable assembly (accessory)
Date, Time:	real time clock with 5 year buffer
Image Overlays:	reticle, model no. or text of your choice, max. 12 characters, time or date, temperature and emissivity

Dimensions: *Metis MQ* with Focusable Optics and Swivel Base HA20

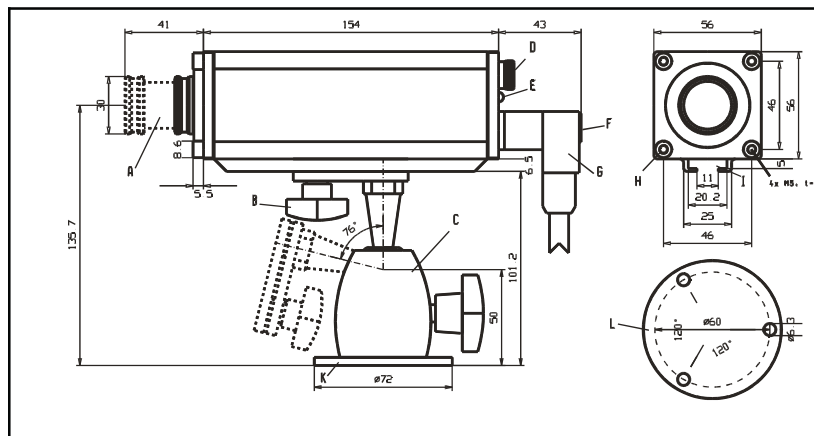

- A: Focusable Optics
- B: Fast-Mount Screw
- C: Swivel Mounting Base
- D: Eye Piece (for models with sight-through optics only)
- E: Operation LED
- F: Laser Push Button
- G: 12-pin Connector
- H: Front-Mount Threads
- I: Mounting Rail
- K: Swivel Base Mounting Flange
- L: Base View of item K with Mounting Holes

Special Accessories available with *Metis MQ* only:

Description	Model
Camera Cable Assembly for Metis MS and MI, length 5 m	AK50-05
Air Purge for Fibre-Optic Lens OL12	BL13-00
Air Purge for Fibre-Optic Lens OL25	BL14-00
Adjustable Mounting Bracket for Fiber-Optic Lens OL12	HA13-00
Adjustable Mounting Bracket for Fiber-Optic Lens OL25	HA14-00
2.5 m Spare Fiber-Optic Cable Metis MS09 and MI16, Ø 0.2 mm	LL02-02
2.5 m Spare Fiber-Optic Cable Metis MI21, Ø 0.4 mm	LL04-02

Notice: For standard Accessories for mounting and protecting the *Metis* Pyrometer series, please refer to the back page of the *Metis* brochure

Process Sensors Corporation

113 Cedar Street
Milford, MA 01757 USA

Tel: (508) 473-9901
Fax: (508) 473-0715

IRTemp@ProcessSensors.com
www.processsensors.com