

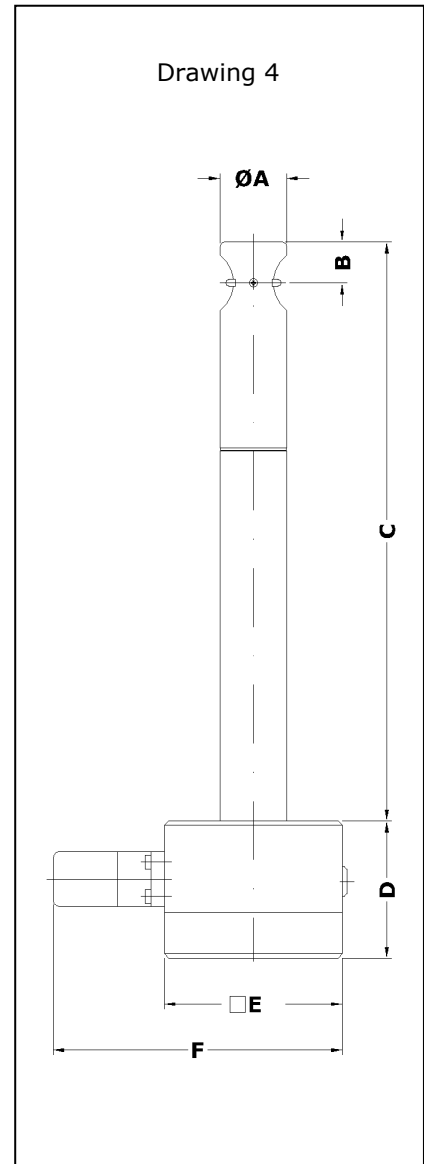

**Flow measurement with sensors ZS25
at working temperatures up to +500 °C
optional with integrated and configurable transducer UFA**



Vane wheel flow sensor ZS25
(see Page 3 for dimensions)

Measurable variable

- standard flow velocity v [m/s] in air/gases

Measuring range

- 0.4 ... 120 m/s

Functional principle

- vane wheel flow sensor
- scanning the vane rotation; non-contact inductive proximity switch

Advantages

- low starting value
- large measuring range span
- maximum fatigue strength thanks to vane wheel which is easy on the bearings
- corrosion resistant
- sterilisable
- high working temperature and pressure ranges
- operates to a large extent irrespective of density and composition of the gas
- low pressure drop
- easy adjustment to process parameter

Design

- insertion probe with AS80 housing

Medium

- air, gas mixtures and clean gases

Range and examples of application

- flow rate measuring, e.g. of air, exhaust gas, process gas
- monitoring laminar flow
- monitoring flow in pharmaceutical works

Humidity in the gas

- relative gas humidity of less than 100 % does not affect the measurement uncertainty



Model designation (example)

ZS25/25	-350	G	E	350	p10	Ex	ZG4
(1)	(2)	(3)	(4)	(5)	(6)	(7)	(8)

Basic types

Type	Transducer/ Output	Article No.
'100 °C' / integrated UFA		
ZS25/25- 250 GE/100/p10/ZG4	UFA-int / 4-20 mA	b002/190-ufa
ZS25/25- 350 GE/100/p10/ZG4	UFA-int / 4-20 mA	b002/191-ufa
ZS25/25- 450 GE/100/p10/ZG4	UFA-int / 4-20 mA	b002/192-ufa
ZS25/25- 550 GE/100/p10/ZG4	UFA-int / 4-20 mA	b002/193-ufa
ZS25/25- 650 GE/100/p10/ZG4	UFA-int / 4-20 mA	b002/194-ufa
'260 °C' / integrated UFA		
ZS25/25- 250 GE/260/p10/ZG4	UFA-int / 4-20 mA	b002/195-ufa
ZS25/25- 350 GE/260/p10/ZG4	UFA-int / 4-20 mA	b002/196-ufa
ZS25/25- 450 GE/260/p10/ZG4	UFA-int / 4-20 mA	b002/197-ufa
ZS25/25- 550 GE/260/p10/ZG4	UFA-int / 4-20 mA	b002/198-ufa
ZS25/25- 650 GE/260/p10/ZG4	UFA-int / 4-20 mA	b002/199-ufa
'370 °C' / integrated UFA		
ZS25/25- 250 GE/370/p10/ZG4	UFA-int / 4-20 mA	b002/200-ufa
ZS25/25- 350 GE/370/p10/ZG4	UFA-int / 4-20 mA	b002/201-ufa
ZS25/25- 450 GE/370/p10/ZG4	UFA-int / 4-20 mA	b002/202-ufa
ZS25/25- 550 GE/370/p10/ZG4	UFA-int / 4-20 mA	b002/203-ufa
ZS25/25- 650 GE/370/p10/ZG4	UFA-int / 4-20 mA	b002/204-ufa
'500 °C' / integrated UFA		
ZS25/25- 250 GE/500/p10/ZG4	UFA-int / 4-20 mA	b002/205-ufa
ZS25/25- 350 GE/500/p10/ZG4	UFA-int / 4-20 mA	b002/206-ufa
ZS25/25- 450 GE/500/p10/ZG4	UFA-int / 4-20 mA	b002/207-ufa
ZS25/25- 550 GE/500/p10/ZG4	UFA-int / 4-20 mA	b002/208-ufa
ZS25/25- 650 GE/500/p10/ZG4	UFA-int / 4-20 mA	b002/209-ufa
'100 °C' / separate evaluation unit		
ZS25/25- 250 GE/100/p10/ZG4	sep. eval. unit / v/FA	b002/190
ZS25/25- 350 GE/100/p10/ZG4	sep. eval. unit / v/FA	b002/191
ZS25/25- 450 GE/100/p10/ZG4	sep. eval. unit / v/FA	b002/192
ZS25/25- 550 GE/100/p10/ZG4	sep. eval. unit / v/FA	b002/193
ZS25/25- 650 GE/100/p10/ZG4	sep. eval. unit / v/FA	b002/194
'260 °C' / separate evaluation unit		
ZS25/25- 250 GE/260/p10/ZG4	sep. eval. unit / v/FA	b002/195
ZS25/25- 350 GE/260/p10/ZG4	sep. eval. unit / v/FA	b002/196
ZS25/25- 450 GE/260/p10/ZG4	sep. eval. unit / v/FA	b002/197
ZS25/25- 550 GE/260/p10/ZG4	sep. eval. unit / v/FA	b002/198
ZS25/25- 650 GE/260/p10/ZG4	sep. eval. unit / v/FA	b002/199



Basic types (cont.)

Type	Transducer/ output	Article no.
'370 °C' / separate evaluation unit		
ZS25/25- 250 GE/370/p10/ZG4	sep. eval. unit / v/FA	b002/200
ZS25/25- 350 GE/370/p10/ZG4	sep. eval. unit / v/FA	b002/201
ZS25/25- 450 GE/370/p10/ZG4	sep. eval. unit / v/FA	b002/202
ZS25/25- 550 GE/370/p10/ZG4	sep. eval. unit / v/FA	b002/203
ZS25/25- 650 GE/370/p10/ZG4	sep. eval. unit / v/FA	b002/204
'500 °C' / separate evaluation unit		
ZS25/25- 250 GE/500/p10/ZG4	sep. eval. unit / v/FA	b002/205
ZS25/25- 350 GE/500/p10/ZG4	sep. eval. unit / v/FA	b002/206
ZS25/25- 450 GE/500/p10/ZG4	sep. eval. unit / v/FA	b002/207
ZS25/25- 550 GE/500/p10/ZG4	sep. eval. unit / v/FA	b002/208
ZS25/25- 650 GE/500/p10/ZG4	sep. eval. unit / v/FA	b002/209

(1) Sensor type / Sensor diameter

Vane wheel flow sensor ZS25 with sensor Ø 25 mm and shaft Ø 25 mm

(2) Sensor length dimension C (see Drawing 4, Page 1)

250 / 350 / 450 / 550 / 650 mm

(3) Medium

... G ... air / gases

(4) Materials in contact with the medium

Design	Material
... E ...	stainless steel 1.4404 / AISI 316L, ceramics Al ₂ O ₃ 99.9 %
'100 °C' and '260 °C'	PTFE lip-seal, Hastelloy spring
'370 °C' and '500 °C'	pure graphite seal

(5) Permissible temperature of the medium

Design	Temperature of the medium
... 100 ...	-20 ... +100 °C (continuous)
... 260 ...	-40 ... +260 °C (continuous) -40 ... +300 °C (short-time)
... 370 ...	-40 ... +370 °C (continuous) -40 ... +400 °C (short-time)
... 500 ...	-40 ... +500 °C (continuous) -40 ... +550 °C (short-time)

ambience	-40 ... +80 °C	with separate evaluation unit
	-40 ... +80 °C	with integrated transducer UFA-int
	-5 ... +50 °C	with optional 'LCD display'



(6) Max. working pressure / Type of protection for sensor

up to 10 bar / 1 MPa kPa above atmospheric
protection class IP68

(7) Option 'Ex'

Type of protection	Art. No.	Comment
Gas-Ex: Category 3G (Zone 2)	faex2	'non-Ex' model conforms to the requirements as per DIN EN 60079-14
Ex ia IIC T6 Gas-Ex: Category 2G (Zone 1)	faex1	only in conjunction with: isolation/supply unit LDX2 <u>and</u> 'non-Ex-evaluation unit' or compatible separate evaluation unit with Ex-input

(8) Design

as in Drawing 4 (Page 1)

dimensions	A Ø 25 mm	B 13.9 mm	C 250/350/450/550/650 mm
	D 60 mm	E 80 mm	F 130 mm

Measurement range (with a gas density of approx. 1.2 kg/m³) / vane wheel type

Measurement range	Vane wheel type	Art. No.
0.4 ... 20 m/s	mn 20 E	v_mn20GE
0.5 ... 40 m/s	mn 40 E	v_mn40GE
1.0 ... 80 m/s	mn 80 E	v_mn80GE
1.4 ... 120 m/s	mn 120 E	v_mn120GE

measurement uncertainty	< 1.5 % of measured value + 0.5 % of terminal value
repeatability	±(0.05 % of terminal value + 0.02 m/s)

Connection housing AS80

dimensions	80 / 80 / 60 mm (L / W / H)
connection	connector GO 070 with terminal screws
terminal assignment	see Page 6
protection class	IP65

Output / transducer (see Pages 2 & 3, 'Basic types')

output 4-20 mA / integrated UFA	UFA integrated in the housing (see Page 6)
output sensor v/FA / separate evaluation unit necessary	Höntzsch evaluation unit with v/FA input necessary for signal evaluation
output sensor v/FA-Ex, sensor with option 'Ex' for use in Category 2G (Zone1) / sep. eval. unit necessary	Höntzsch evaluation unit with intrinsically safe v/FA-Ex signal input or with v/FA input in conjunction with a series connected isolation/supply unit necessary for signal evaluation



Accessories		
	Description	Article no.
	calibration certificate v/FA	klbneu
standard calibration value depending on vane wheel type, others see Data Sheet U183	mn 20 E: 1; 2; 5; 10; 15; 20 m/s mn 40 E: 1; 2; 5; 10; 20; 30 m/s mn 80 E: 1; 5; 10; 20; 40; 60 m/s mn120 E: 1; 5; 10; 20; 40; 60 m/s	
probe guide piece SFB 25 E-54 / G 1 1/4" ZG5 with bushing as in drawing 5	for any repeated positioning with marginal excess pressure (max. 1.5 bar/ 150 kPa) / low pressure, through hole 25 mm, connection by screw thread sleeve or ball valve with inside thread G 1 1/4", working temp. range -20 ... +240 °C, intallation length 54 mm, materials: stainless steel, VITON®, PTFE bushing	b004/510
probe guide piece SFK 25 E-100 / G 2" ZG2 with clamping yoke as in drawing 2	for any repeated positioning even with higher excess pressure (max. 10 bar/1 MPa) / low pressure, through hole 25 mm, connection by screw thread sleeve or ball valve inside thread G 2", working temp. range -20 ... +240 °C, installation lenght 100 mm, materials: stainless steel, VITON® lip-seal, incl. hook spanner and hexagon screw driver	b004/210
probe guide piece SFB 25 E-70 / F-DN50 PN16 ZG1 for max. +550 °C as in drawing 1	For any repeated positioning with lower pressures above atmospheric (max. 2 bar / 200 kPa) / subatmospheric pressures, working temperature range -40 ... +550°C, through hole 25 mm, to single ended flange nipples or ball valve with flange, probe attachment by clamping bush, materials: stainless steel, graphite, flange DN50 PN16 in conformity with DIN, installation length L 70 mm	b004/110

Probe guide piece drawing 1

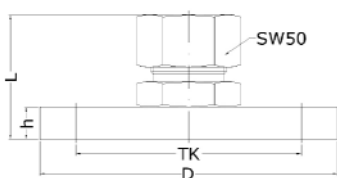

Probe guide piece drawing 2

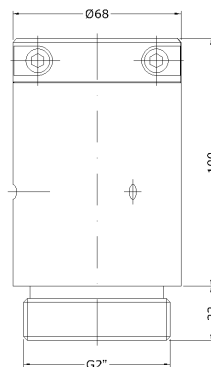

Probe guide piece drawing 5

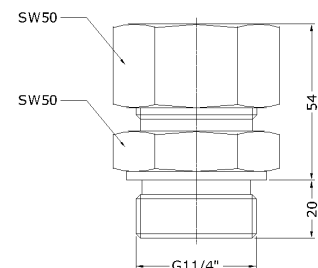



Transducer UFA-int, integrated in the sensor connection housing

analog output/resistance	4 ... 20 mA = 0 ... ___ m/s, resistance max. 400 Ohm
output 'limit value' or 'quantity pulse'	Open Collector / max. 50 mA / max. 27 V DC, pulse duration 0.5 s
PC interface	RS232
	output signals electrically isolated from the power supply
self-monitoring	parameter settings, sensor interface; in case of error: analog output less than 3.6 mA
connection	connector GO 070 with terminal screws
power supply	24 V DC (20 ... 27 V DC)
power consumption	less than 3 W
working temp. range	-40 ... +80 °C
housing	sensor connection housing AS80
EMC	EN 61 000-6-2:2001
setting parameter	analog output, profile factor/coefficient, pipe inside diameter, time constant, sensor type, measurement range, medium, limit value or quantity pulse (valency adjustable), switching actual/standard flow with setting parameters, 'actual pressure' and 'actual temperature' ...
setting parameter with PC software UCOM and programming adapter (see below) changeable	

Accessories (cont.) / options

	Description	Art. No.
LCD display in housing cover	2 x 16 digit, numerals 3 mm high, working temperature range -5...+50 °C	a010/007
PC software UCOM	for configuring the UFA/int via RS232	a010/052
programming adapter G0 070 / RS232	for software UCOM, connection PC Sub-D 9-pin, power plug 230VAC/24VDC	a010/004
interface converter USB / RS232	PC connection : USB plug type A on instrument : Sub-D 9-pin	a010/100



optional LCD display in the housing cover

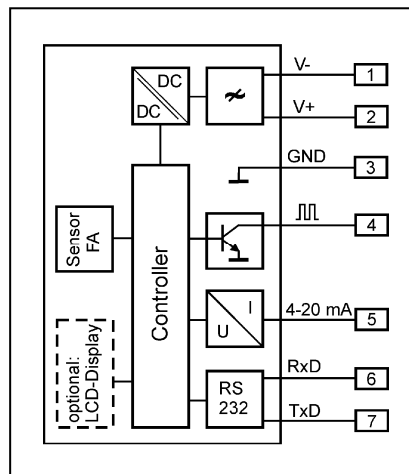

Wiring diagram with integrated UFA

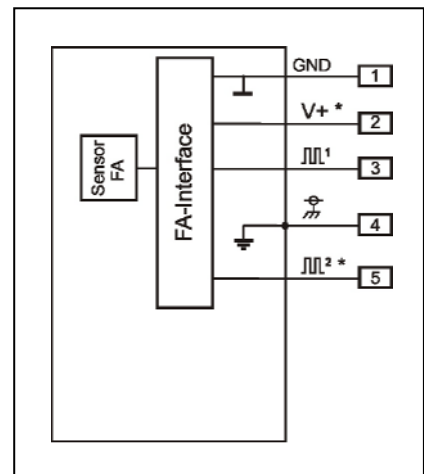

Wiring diagram sensor for separate evaluation unit (* optional)

Höntzsch GmbH

Gottlieb-Daimler-Straße 37
D-71334 Waiblingen (Hegnach)
Tel: +49 7151 / 17 16-0
Fax: +49 7151 / 5 84 02
E-Mail info@hoentzsch.com
Internet www.hoentzsch.com

Subject to alteration

All prices net in EUR. Delivery ex works Waiblingen, postage and packing extra plus current rate of VAT.

Valid from November 2005